

DATA SHEET

Sirman Raviomatic Ravioli Maker

40111562-1



Build

- Innovative design revolutionizes fresh ravioli production in professional kitchens with a patented system.
- Easily connects to Sirman Concerto 5 or Orchestra 10 pasta machines for on-demand ravioli production.
- Create single-layer extruded ravioli in various shapes and sizes, with fillings ranging from classic cheese and vegetables to seafood and poultry.
- Multiple interchangeable molds allow for a variety of ravioli shapes and sizes, enabling customization to suit any menu offering.
- Each component in contact with the pasta can be easily dismantled, allowing for efficient and rapid cleaning to maintain high hygiene standards.
- Various dies for different sheet thicknesses 0.8mm and 1mm
- Features a practical filling adjustment mechanism for optimal filling amounts, enhancing quality and consistency.
- Equipped with a variable-speed independent motor that adapts to different machines and flow rates, ensuring smooth operation.
- All components in contact with pasta can be quickly dismantled for thorough cleaning, maintaining hygiene standards without interrupting kitchen workflow.
- Made from high-quality materials, including electro-polished AISI 304 stainless steel and anodized aluminum, ensuring durability and maximum hygiene.
- The cylinder is constructed from electro-polished AISI 304 stainless steel, ensuring durability, resistance to corrosion, and maximum hygiene in food preparation.
- The funnel and pad are made from POM-C, a high-quality, durable material that ensures excellent wear resistance and maintains hygienic standards in food production.
- The filling cup is made of AISI stainless steel, providing durability and ensuring high hygiene standards in the ravioli production process.
- The metal panels that hold the sheet of pasta are made of AISI 304 stainless steel with a QuanTanium coating, enhancing durability and providing excellent non-stick properties for improved performance.
- The molds are constructed from anodized aluminum, offering enhanced durability and ensuring maximum hygiene during the ravioli production process.
- TPU conveyor belt certified for food contact, enhancing safety in the ravioli-making process.
- Enhances menu offerings with fresh, artisanal ravioli while improving production efficiency in any pasta establishment.



Technical specifications

External Size

External Width	311mm
External Depth	346mm
External Height	561mm

Weight

Net weight	20 kg
package weight	*

Connection requirements electric

Electrical connected loads	100W
Voltage	240 V
Plug Supplied	10A

Warranty

2 Year Warranty	2 years parts and labour
-----------------	--------------------------

**Subject to a preventative maintenance plan*

DATA SHEET

Sirman Raviomatic Ravioli Maker

40111562-1



Optional accessories

Filling Cylinder

<input type="checkbox"/>	S/steel support cylinder	
	SKU	40111570
<input type="checkbox"/>	Kit funnel from mm ø8	
	SKU	LF02300025
<input type="checkbox"/>	Kit funnel from mm ø12	
	SKU	LF02300030



Ravioli Dies

<input type="checkbox"/>	Large ravioli 0.8 mm	
	SKU	LF202505330
<input type="checkbox"/>	Large ravioli 1 mm	
	SKU	LF202505331
<input type="checkbox"/>	Small ravioli 0.8 mm	
	SKU	LF202505333
<input type="checkbox"/>	Small ravioli 1 mm	
	SKU	LF202505334



Device for interchangeable moulds

<input type="checkbox"/>	Device for interchangeable moulds	
	SKU	LF02300110100



Interchangeable moulds

<input type="checkbox"/>	Rettangolare piccolo seghettato 63 x h.45mm	
	SKU	LF20250136A
<input type="checkbox"/>	Rettangolare grande seghettato 94 x h.52mm	
	SKU	LF20250136B
<input type="checkbox"/>	Mezzaluna piccolo seghettato 63 x h.45mm	
	SKU	LF20250136C
<input type="checkbox"/>	Mezzaluna grande seghettato 94 x h.55mm	
	SKU	LF20250136D
<input type="checkbox"/>	Schlutzkrapfen mezzaluna piccolo liscio 63 x h.39mm	
	SKU	LF20250136E
<input type="checkbox"/>	Triangolare 94 x h.45mm	
	SKU	LF20250136G
<input type="checkbox"/>	Schlutzkrapfen mezzaluna grande liscio 94 x h.45mm	
	SKU	LF20250136H
<input type="checkbox"/>	Quadrato seghettato 37 x h.37mm	
	SKU	LF20250136I
<input type="checkbox"/>	Cuore 63x45mm	
	SKU	--



Interchangeable teflon moulds

<input type="checkbox"/>	Rettangolare piccolo seghettato 63 x h.45mm	
	SKU	LF20250137A
<input type="checkbox"/>	Rettangolare grande seghettato 94 x h.52mm	
	SKU	LF20250137B
<input type="checkbox"/>	Mezzaluna piccolo seghettato 63 x h.45mm	
	SKU	LF20250137C
<input type="checkbox"/>	Mezzaluna grande seghettato 94 x h.55mm	
	SKU	LF20250137D
<input type="checkbox"/>	Schlutzkrapfen mezzaluna piccolo liscio 63 x h.39mm	
	SKU	LF20250137E
<input type="checkbox"/>	Triangolare 94 x h.45mm	
	SKU	LF20250137G
<input type="checkbox"/>	Schlutzkrapfen mezzaluna grande liscio 94 x h.45mm	
	SKU	LF20250137H
<input type="checkbox"/>	Quadrato seghettato 37 x h.37mm	
	SKU	LF20250137I
<input type="checkbox"/>	Cuore 63x45mm	
	SKU	--



Ravioli moulds

<input type="checkbox"/>	ST. RAVIOLI RETTANG.IRR.PICC.SEGHETT	
	SKU	40111600A
<input type="checkbox"/>	ST.RAVIOLI MEZZALUNA PICC.SEGHETT	
	SKU	40111600C
<input type="checkbox"/>	ST.RAVIOLI MEZZALUNA GRAN.SEGHETT	
	SKU	40111600D
<input type="checkbox"/>	ST.RAVIOLI MEZZALUNA PICC.LISCIO	
	SKU	40111600E
<input type="checkbox"/>	ST.RAVIOLI TRIANGOLARE	
	SKU	40111600G
<input type="checkbox"/>	ST.RAVIOLI MEZZALUNA GRANDE LISCIO	
	SKU	40111600H
<input type="checkbox"/>	ST.RAVIOLI QUADRATO C/CAPPE 37x37	
	SKU	40111600I



Connection kits

<input type="checkbox"/>	Connection kit orchestra 10	
	SKU	LF202505338
<input type="checkbox"/>	Connection kit Concerto 5	
	SKU	LF202505340



We reserve the right to alter specifications without notice.

DATA SHEET

Sirman Raviomatic Ravioli Maker

40111562-1

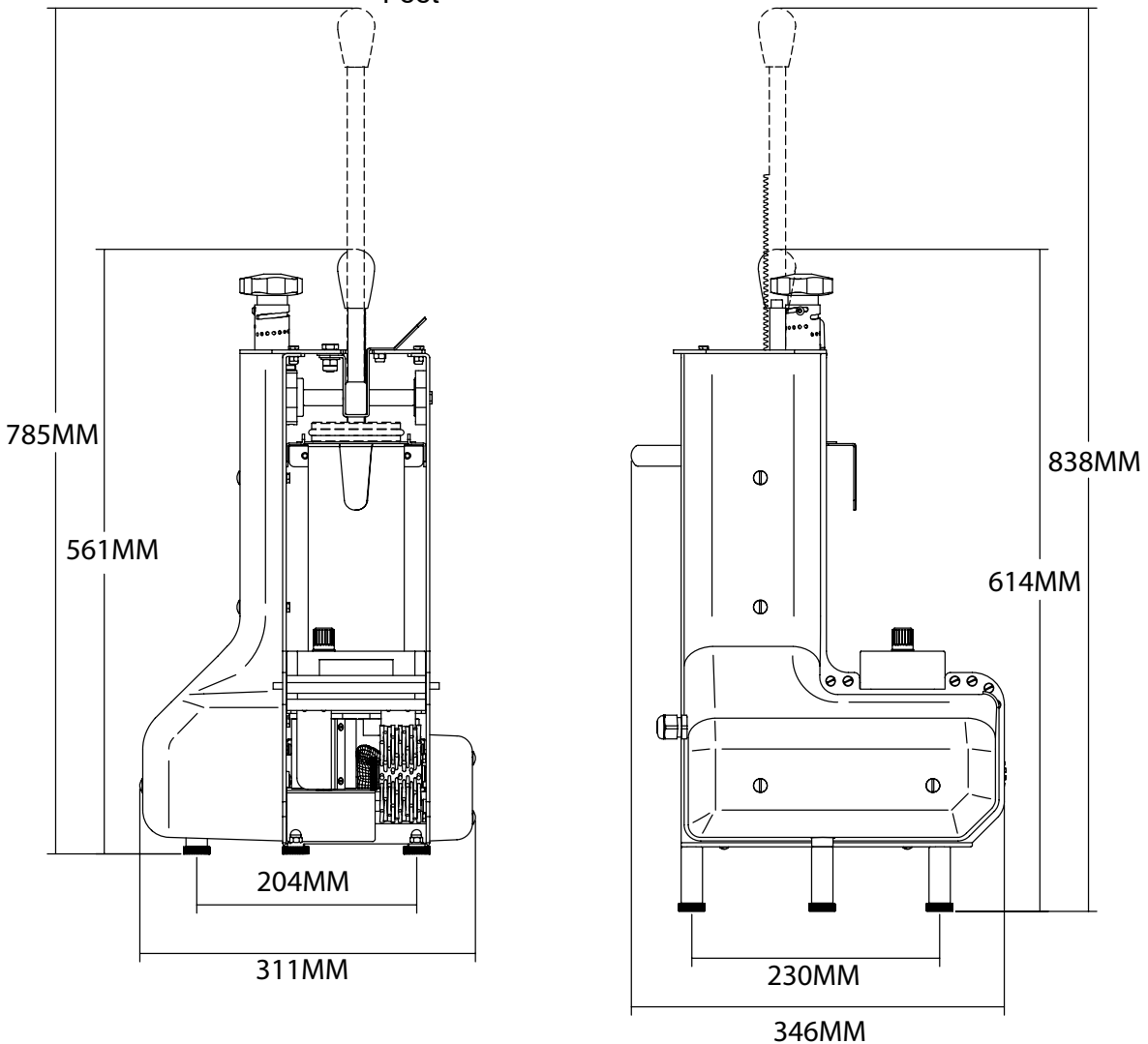
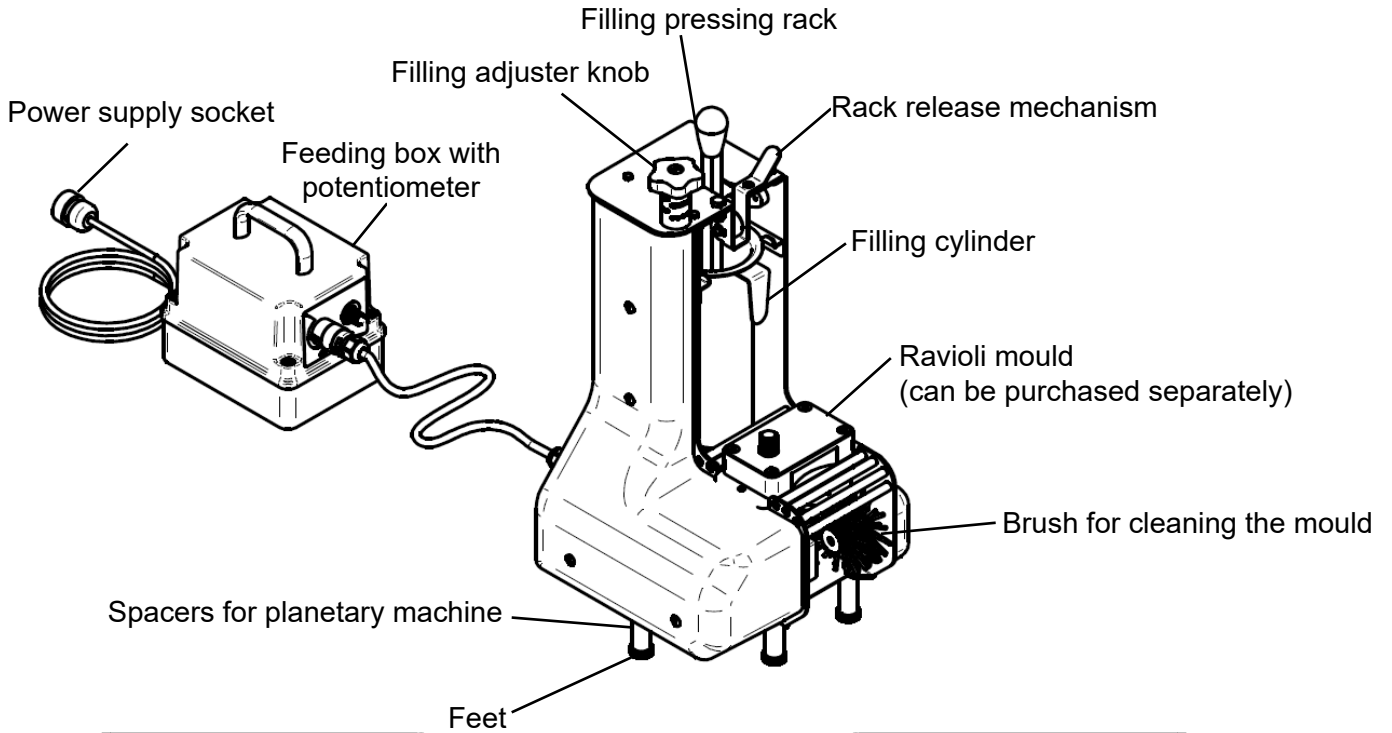

We reserve the right to alter specifications without notice.