

DATA SHEET

Sirman Orchestra 10T Benchtop Pasta Machine - 21 Litre Capacity | 9.8 kg Batch

84381090-1



Build

- Benchtop design allows for high-volume fresh pasta production, ideal for establishments seeking significant output.
- Extensive range of interchangeable dies enables chefs to create various pasta shapes and sizes maximising menu versatility.
- Independent controls for mixing the pasta dough and extrusion ensure precise kneading and optimal output, resulting in consistently high-quality pasta.
- 21-liter tank capacity accommodates batch sizes of up to 9.8 kg.
- Produces approximately 20 kg of fresh pasta per hour.
- Equipped with a \varnothing 110 mm die size for efficient operation tailored to medium to large establishments.
- IP67-rated stainless steel waterproof controls ensure dependable operations and longevity.
- Powerful 3-Phase Air-cooled motor paired with an oil bath gearbox reducer minimizes overheating and ensures reliable performance during extended operation.
- Heavy Gauge Kneading paddle with Interlocked design for Easy-to-remove allowing for effortless cleaning and maintenance.
- Kneading paddle designed with multiple arms for gentle mixing to achieve the perfect texture prior to extrusion.
- Removable funnel for seamless addition of liquid ingredients.
- Heavy Duty Stainless steel worm, head, and ring contribute to the machine's longevity and reliability.
- Interlocked stainless-steel lid with a safety microswitch enhances operational safety.
- Constructed entirely from AISI 304 stainless steel, the Orchestra 10T features a heavy-gauge, reinforced anodized aluminum tank that ensures robustness while facilitating easy maintenance.



Technical specifications

External Size

External Width	628mm
External Depth	778mm
External Height	493mm

Weight

Net weight	72 kg
package weight	*

Connection requirements electric

Electrical connected loads	2.25W
Voltage	415 V
Plug Supplied	No

Technical Fixtures

Litre Capacity	21L
Production Capacity	20kg/hr
Batch Quantity	9.8kg
Die Size	110mm

Warranty

2 Year Warranty	2 years parts and labour
-----------------	--------------------------

*Subject to a preventative maintenance plan

DATA SHEET

Sirman Orchestra 10T Benchtop Pasta Machine - 21 Litre Capacity | 9.8 kg Batch

84381090-1



Optional accessories

<input type="checkbox"/>	Pasta Cutter
SKU	40117120

<input type="checkbox"/>	Tray holder
SKU	LF202510062

<input type="checkbox"/>	Pasta Dryer Rack
SKU	LF202510068

<input type="checkbox"/>	Adjustable Sheeter
SKU	28183000

<input type="checkbox"/>	Spaghetti 1.9mm
SKU	28183009

<input type="checkbox"/>	Bigoli / Pici Toscani 3mm
SKU	28183013

<input type="checkbox"/>	Linguine 3x1.6mm
SKU	28183021

<input type="checkbox"/>	Linguine 3.5x1.6mm
SKU	28183021A

<input type="checkbox"/>	Spaghetti Quadri / Chitarrine 1.8mm
SKU	28183025

<input type="checkbox"/>	Spaghetti Quadri / Chitarrine 2.5mm
SKU	28183026

<input type="checkbox"/>	Tagliatelle 6mm
SKU	28183034

<input type="checkbox"/>	Pappardelle 15mm
SKU	28183038

<input type="checkbox"/>	Reginette 12MM
SKU	28183055

<input type="checkbox"/>	Maccheroni Lisci 25mm
SKU	28183069

<input type="checkbox"/>	Maccheroni rigati 8mm
SKU	28183077

<input type="checkbox"/>	Maccheroni rigati 10mm
SKU	28183078

<input type="checkbox"/>	Maccheroni Rig 20mm
SKU	28183081

<input type="checkbox"/>	Casarecce/Strozzapreti 8.8mm
SKU	28183220

<input type="checkbox"/>	Fusilli 8.4mm
SKU	28183240

<input type="checkbox"/>	Fusilli 15.5mm
SKU	28183242

<input type="checkbox"/>	Conchiglia Rustica
SKU	28183388

<input type="checkbox"/>	Paccheri
SKU	28183397

<input type="checkbox"/>	Penne 8.5mm
SKU	28183116

<input type="checkbox"/>	Knife
SKU	40117112

<input type="checkbox"/>	Maccheroni Rigati 15mm
SKU	--

<input type="checkbox"/>	Orecchiette
SKU	--

<input type="checkbox"/>	Custom standard Die
SKU	--

<input type="checkbox"/>	Custom Penne Die
SKU	--

We reserve the right to alter specifications without notice.

DATA SHEET

Sirman Orchestra 10T Benchtop Pasta Machine - 21 Litre Capacity | 9.8 kg Batch

84381090-1

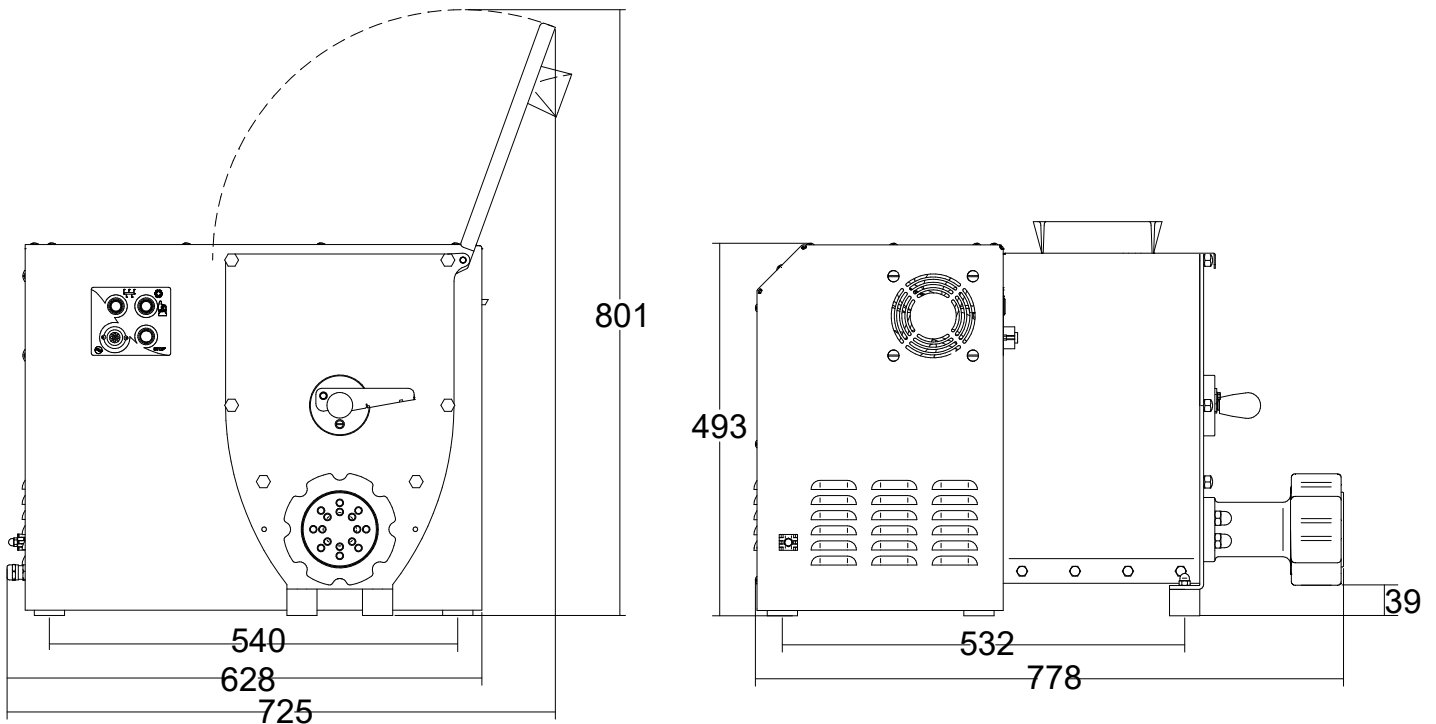
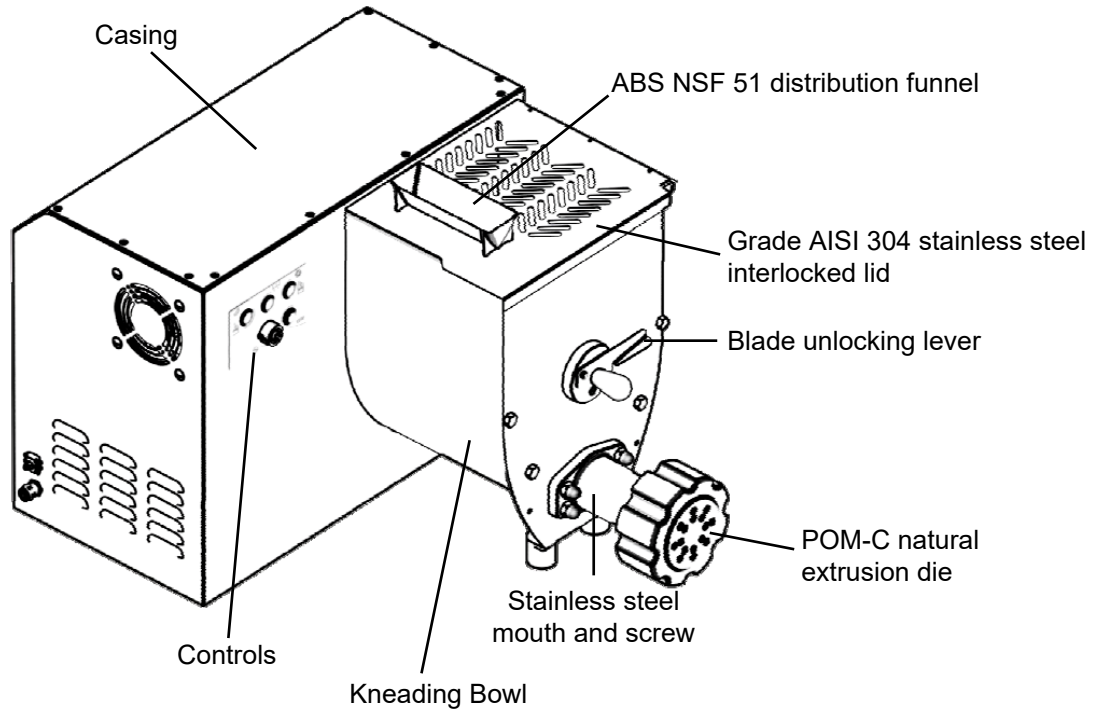

We reserve the right to alter specifications without notice.



1800 183 818

support@thegoodlady.com.au

www.thegoodlady.com.au